

LASER³

All in one next generation solid state laser marking

- Ultra compact size
- High-reliability
- Extended life time over 20.000 hours
- Low running costs
- State of the art technology and performance
- Embedded full digital electronic control
- Actively stabilized air cooled system
- Designed for OEM applications, customized solution and on line production
- Remote diagnostic over Internet connection



Small is better



The Laser Way

ANY APPLICATION HAS A POSSIBLE LASER ALTERNATIVE

MARKING LASER SYSTEMS

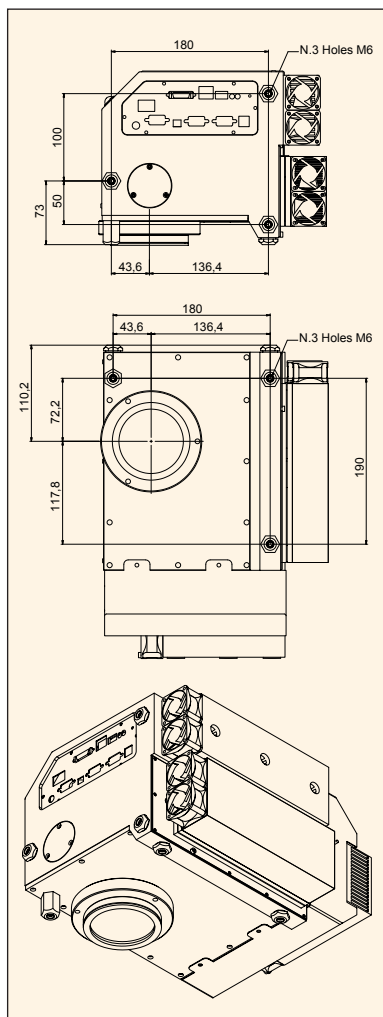

Caratteristiche Tecniche **LASER³**

Laser Source	Diode pump solid state technology
Scan Head	High definition 2 axis galvo "Full Digital"
Power Max	12 W
Wavelength	1064 nm
Pulse repetition frequency	0-100 KHz
Pulse stability (%)	> 90 %
Peak power (max)	> 130 KW
Beam quality factor M ²	< 1,5
Cooling	Actively stabilized by 'Thermo-Electric Cooled'
MTBM	20.000 h
Beam expander	Dynamic control of the fire spot
Marking path	Sealed and dust free optic path IP56
Hardware controller	DSP microprocessor, 128 MB Ram, Backup buffer 8 MB
Interface	LAN Ethernet 10-100 Mb/s, RS 232/485 linking, digital I/O for synchronized automations and diagnostic, input for external encoder (marking on the fly), automation input/output interfacing
Power Laser sensor	Direct monitoring of diodes and optical power output
Pre-view System	Diode integrated in the laser marking head
Marking Software	ICARO for Windows 98, NT, 2000, XP
Alimentation	1/N/PE AC 230V +-10% / 50-60Hz / 600W / 2.6 A
Dimensions W x L x H	358 x 290 x 150 mm
Weight	16 Kg
Air flow	90 m ³ /h
Temperature use	15° - 35 ° C

SEI SpA reserves the right to modify the characteristics without notice.
All logos and trademarks mentioned belong to their legitimate owners.



ATTENZIONE!!!

RADIAZIONE LASER VISIBILE ED INVISIBILE
EVITARE L'ESPOSIZIONE DELL'OCCHIO E DELLA
PELLE ALLA RADIAZIONE DIRETTA O DIFFUSA
APPARECCHIO LASER CLASSE 4

COMPANY
WITH QUALITY MANAGEMENT
SYSTEM CERTIFIED BY DNV
=ISO 9001:2000=



LASER³ is the latest laser marking system exploiting long life DPSS technology operating within the infrared spectrum (1064nm). Besides an extremely compact size, the main feature of this laser system is the so called "**All in One**" solution: the laser cavity, scan head and full digital electronic control are fitted in a unique **small cube measuring** just 360 x 260 x 200 mm.

LASER³ meets the growing demand in the bar **coding** and **laser marking** markets for product traceability and flexible programmable processes. **LASER³** is ideally suited to **marking logos, alphanumeric codes, bi-three dimensional bar codes** (data matrix) on materials such as **plastics, silicon** and **PCB surfaces**. Thanks to the high peak power available it removes coatings on both flat and uneven surfaces with extraordinary high accuracy (TEM00 output with M2<1.5 and lower spot sizes than 25 microns).

Another advantage of the system is a high thermal stability: **LASER³** avails itself of fan air-thermostable cooling system **TEC thermo-electric cooled technology** providing a constant temperature output in the range of 10 to 40°C. The estimated average laser output is over 20,000 (MTBM).

LASER³ is designed to work in a stand alone mode (without PC) and mark on the fly as a part of a production line. **LASER³** is also equipped with digital I/O's serial ports RS 232/ 485 and can be connected to a LAN 10/100 network. The flexible design enables the system to be configured for **OEM** users.

LASER³ is a **class 4** system and complies with international safety standards (CEI EN 60825-1).

SEI SpA

Via Ruffilli, 1 - 24035 CURNO (BG) Italy
Tel. +39 035 5788900 / +39 035 4376016 - Fax +39 035 463 843
Web: www.seilaser.com - e-Mail info@seilaser.com